

project specification

fixture type                      D767 series LV mini Horizontal Tape [ two wire ]

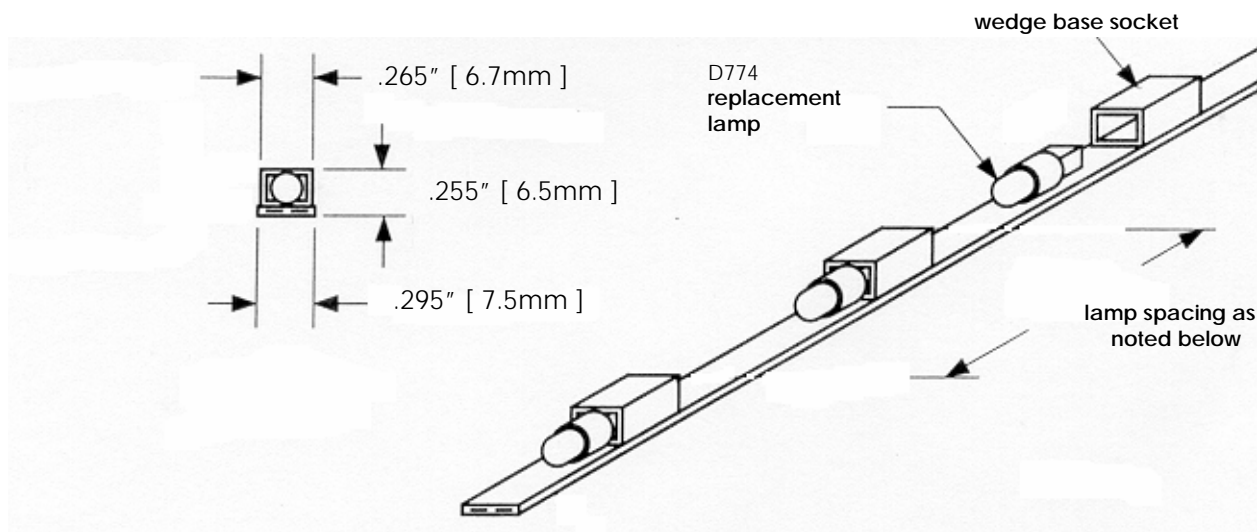

Job Name:  
 Job Nbr:  
 Tag:  
 Distributor:  
 Electrician  
 Engineer:  
 Interior Design:  
 Architect:  
 note: site measurements required

Note:  
 Any Changes or modifications to mmj lighting 96 ltd lighting fixtures, must be done in the mmj lighting 96 ltd factory. Any modifications or changes done in the field will void all warranties and approvals.

**Specifications: Two wire LV mini Horizontal tape.**

**Lamp spacing:**

D767	2" o.c.,	D768	3" o.c.
D769	4" o.c.	D770	6" o.c.
D771	8" o.o.		

**Accessories:**

D743 two sided tape,  
 D773 end caps.

**Replacement lamp:**

D774 replacement lamp. [ 20,000 hour lamp life ]

**Power feed:**

A182 power feed included in quotation with each run.  
 Shrink tube [ supplied by mmj 96 with each order ]  
 must be used when installed in extrusions listed below.

**For transformers see binder section 7.**

**Available extrusion: see binder section 2.**

D777 see spec sheet  
 D235P LV Path carpet to floor.  
 D236P LV Path carpet to carpet.  
 D237P LV Path carpet to wall.  
 D238P LV Path twin strip bull nose step extrusion.

Shop drawing lv mini two wire horizontal tape 1.20.04

